

**INSTALLATION OPTION
J-HOOKS ENGAGED TO TENDONS**

STEP 1: MAKE 2 LOOPS IN THE TENDON.

STEP 2: PULL LOOP 1 PARTIALLY THROUGH LOOP 2.

STEP 3: INSERT THE J-HOOK ANCHOR THROUGH LOOP 1 AND DRIVE J-HOOK INTO THE GROUND UNTIL THE TOP OF THE HOOK IS LEVEL WITH THE TOP OF THE CELLTEK SECTION.

STEP 4: PULL BOTH ENDS OF TENDON TO CLOSE THE LOOP AND DRIVE J-HOOK UNTIL THE TOP OF IT IS FLUSH WITH GROUND SURFACE.

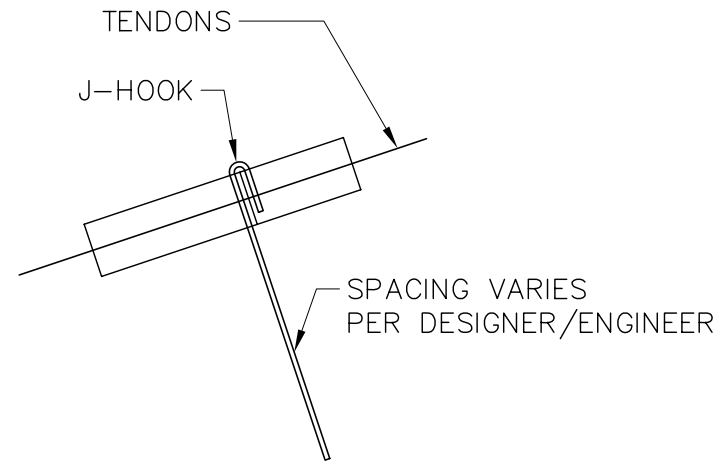

**INSTALLATION OPTION
J-HOOK ENGAGED TO CELLS**

TENDONS PRE-THREADED THROUGH INDIVIDUAL CELLTEK SECTION PRIOR TO EXPANDING SYSTEM

POSITION STAKE NEXT TO CELL WALL.

DRIVE STAKE INTO THE GROUND UNTIL FLUSH WITH TOP OD CELL WALL.

GRANULAR INFILL CELLTEK SECTION MATERIAL SPECS PER ENGINEER

AASHTO M288 CLASS II NONWOVEN GEOTEXTILE

VARIES
1

COMPACTED EARTH PER ENGINEER

MIN. 1/2" STAPLES TO CONNECT GRIDSM CELL WALLS, OR CELL ENDS

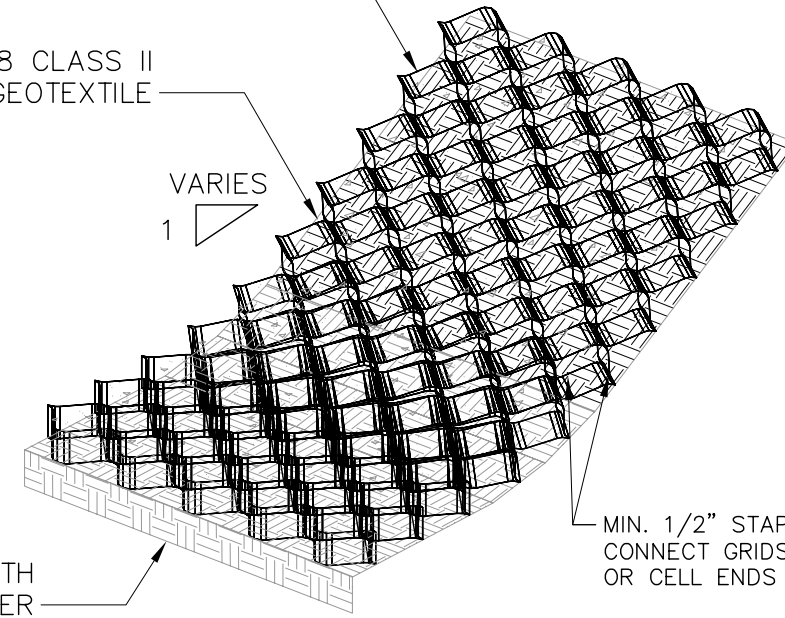

WRAP EDGES

GRANULAR/WASHED AGGREGATES INFILL CELLTEK SECTION MATERIAL SPECS PER ENGINEER

AASHTO M288 CLASS II NONWOVEN GEOTEXTILE

PREFORATED CELLTEK SECTION

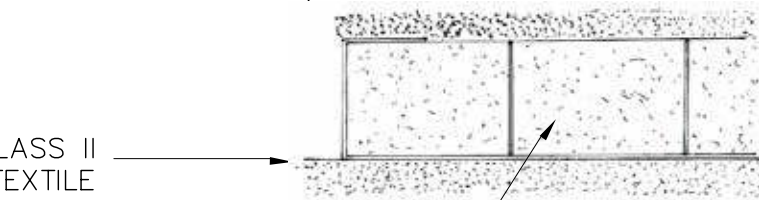

ANCHORING OPTIONS

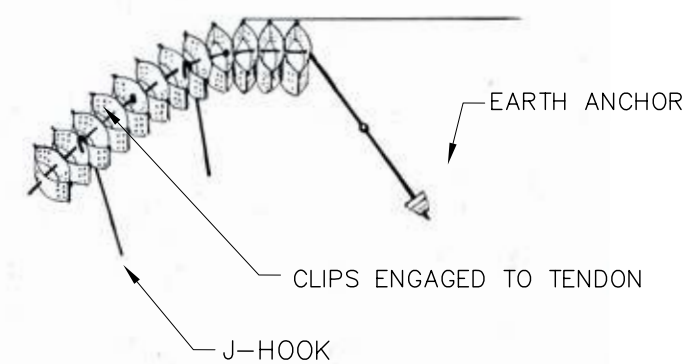
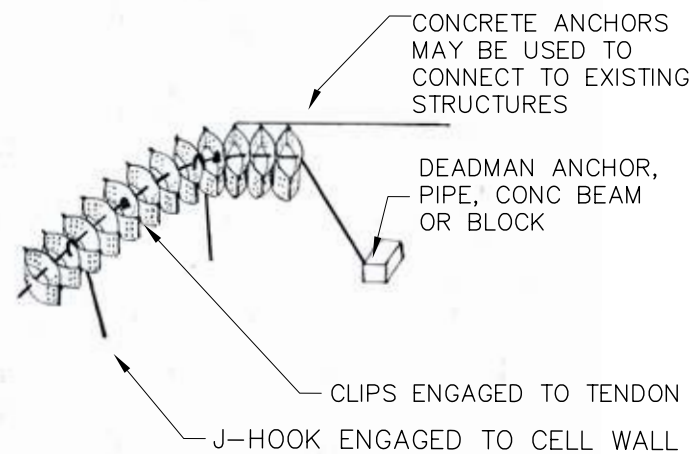
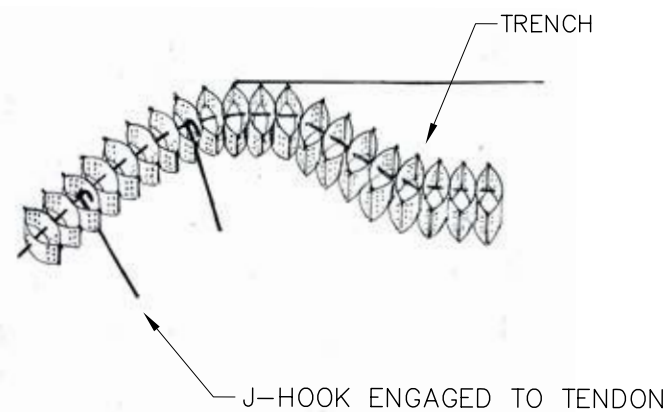

DRAWN BY:	JK	01/30/18	SHEET 1
CHECKED BY:	JK		

AGGREGATE SURFACE LAYER

SLOPE-TEK

SLOPE PROTECTION

CELL-TEK
synthetics

TOLL FREE 888-851-0051
WWW.CELLTEKDIRECT.COM